

[Title] JoSS Article Preparation Instructions and Template

[Topic Area – See list of acceptable topics at <https://jossonline.com/about>]

FirstName A. LastName and FirstName B. LastName

Research Affiliation

City, State, Country

FirstName C. LastName

Different Research Affiliation

City, State, Country

Corresponding Author Name – Email address (for publication)

[Please list, either here or in a cover letter/email, the email addresses and telephone numbers for ALL Authors, for JoSS files and any urgent communication about the article should we not be able to reach the primary Author.]

ABSTRACT

To provide a standardized presentation for Reviewers and Editors, this file template is to be used for articles and any subsequent revisions submitted for possible publication in JoSS. Each sentence of this text provides specific formatting guidelines. The pdf file is the more permanent reference file for this purpose; the word file version may be used to insert the text of a submission into the template. A succinct, accurate, and searchable title should be centered, bold, in Roman font style, and the only text in 12-pt. typeface. Immediately below this, the appropriate topic area of the submission should follow below the title, for JoSS internal use only. Please see the list of acceptable topic areas provided on the website at www.jossonline.com/about. Following the title and topic area is the single-spaced Author block, with the Author's name (no initials other than middle or secondary names), and in italics, the Author's research affiliation and abbreviated address, as shown. The Corresponding Author's name and email address should be noted beneath the Author block(s), for publication. We also request the Corresponding Author's preferred telephone number for any possible urgent contact, as well as email addresses for each credited Author, as indicated, for JoSS files only (not for publication). A single-paragraph, left-justified, double-spaced Abstract should follow the Author information, led by its centered heading in boldface and all caps. The abstract should not exceed 260 words in length, and should not contain mathematical expressions, footnotes, citations, figures, tables, or first-person sentence structure. A horizontal line should separate the Abstract from the body of the text.

1. Introduction

The text in the Abstract and throughout the rest of the manuscript should be 10-pt. typeface, and also in Roman or similar font style. (Figure captions and Table titles should be in 9-pt. typeface.) All text should be left-justified and double-spaced, except for the author block following the title, which is single-spaced. All margins should be 1",

and the first line of each paragraph should be indented by 0.25" (6 cm). There should be single spacing between sentences.

Maximum article file size is 10 megabytes, with authorized exceptions.

The following sections will outline formatting guidelines for headings, math, figures, and tables using Microsoft Word.

2. Formatting Sections

The text should be divided into sections, each with a separate heading at the left margin and numbered consecutively. There should be no number designation if there is only one section or sub-section at this level. There should be no special-headings other than Abstract, Acknowledgments, Appendices, and References. Each of these special, all-capped, centered, bolded headings should be two lines below the text they follow. All subsection headings should be formatted on a separate line, and as described below.

2.1 Secondary Headings and an Example of How to Format any Heading that Requires More Than One Line for its Title

Subsections (secondary headings) are formatted at the margin, bold, initial caps only, and numbered, as shown above. If there is only one subsection, it is unnumbered. All subsection, sub-subsection, and quaternary headings are preceded and followed by just one blank line (i.e., they are double-spaced).

2.1.1 Tertiary Headings

Sub-subsections requiring tertiary numbering (as shown here) are formatted in bold, with initial caps and indented, as shown. If there is only one, then it is unnumbered. Otherwise, use a leading lower number designation as shown: 2.1.1, 2.1.2, 2.1.3, etc. The number designation is shown here to demonstrate, though there is only one tertiary section heading.

Quaternary Heading

This is the formatting for any fourth-order headings that may be necessary. In the Author's discretion, multiple quaternary sections may have an ordinal designation (i.e., "(a)", "(b)", "(c)", etc.), though it is not required.

2.2 Bulleted or Numbered Lists

Bulleted or numbered lists should be consistently formatted, using the following guidelines:

- *Designation.* List items may be designated with either bullets or ordinal numerals, as appropriate.
Numbered list items should be led by 1., 2., 3., etc.
- *Indentation.* List items in paragraph form should have no first-line indent.

- *Headings*. If there is a phrase or “heading” for each individual list item, use italics and follow it with a period, colon, or hyphen. Omit this punctuation, if the “heading” is part of a sentence.

2.3 Citations

Citations are correctly written within the text following the referenced information as a parenthetical with author’s last name and date of publication: (Smith et al., 2003). DO NOT EMBED LINKS for either citations or Figures/Tables. Every citation should have a matching reference in the References section at the end of the article, and all references in the References section must be cited in the text. Unpublished material should be referred to parenthetically in the text as a personal communication and may be included in the Reference list at the Author’s discretion, as “Unpublished.”

3. Formatting Math

The following sections will outline the basic formatting rules for mathematical symbols and equations.

3.1 Mathematical Symbols

Symbols must be of the same font style both in text discussion and in displayed equations or terms (and figures should be prepared to match). Scalar single character symbols are set italic, Greek, or script. Examples are u , L , w , x , y , z , f , σ , g , r , indices such as i or j , and constants such as C_D , k , or K . Note that Greek upsilon υ is used for ν (italic “vee”) to avoid confusion with Greek nu ν , often used for viscosity. Multiple character scalar variables, abbreviations, non-dimensional numbers, and acronyms for variables are set as regular non-italic: LWC, Re, Ro, BT_{sfc} , abs, obs, max, min, Re/Im (real/imaginary), etc. For vectors, use boldface non-italic Times Roman as in \mathbf{V} , \mathbf{v} , or \mathbf{x} , and \mathbf{i} , \mathbf{j} , and \mathbf{k} unit vectors. For matrix notation, use non-italic Arial boldface font as in \mathbf{A} , \mathbf{B} , or \mathbf{M} . Arial boldface font is also used for linear operators. Nonlinear operators and special functions (e.g., Heaviside function) can be set as a script variable: \mathcal{H} . All mathematical operator abbreviations/acronyms are set lower-case regular Roman font, except O (on the order of), which is set italic: $O(10^2)$, sin, cos, tan, tanh, cov, Pr (for probability; note same as Prandtl number), const (for constant), c.c. (complex conjugate).

3.2 Equations

Brief equations or terms set inline in text must be set as a single line expression, if possible, because publication-ready pages are not double spaced -- for example, $\rho^{-1}p/x$ or $(1/\rho) p/x$ or $(a - b)/(c - d)$. Also, please enter them directly from the keyboard, if possible. For more complex variables that have both subscripts and superscripts, or have a more complicated operator such as a radical sign, use of the MathType equation editor is recommended:

σT_b^4 , $\sqrt{x^2 + y^2}$, p_{stc}^2 . In the case of a more complicated term or equation, it should be set as an unnumbered display equation, such as

$$x = \frac{2b \pm \sqrt{b^2 - 4ac}}{2c},$$

or as a numbered equation if it is to be referred to again or is a part of a derivation, as shown in Eqn. (1) below:

$$x = \frac{2b \pm \sqrt{b^2 - 4ac}}{2c}. \quad (1)$$

In either case, punctuate after the equation as if part of the sentence.

Display equations should be indented, unless they are relatively short, in which case they may be centered. Equation numbers should be sequential, in parentheses, and aligned with the right-hand margin. References in the text to numbered equations should use the abbreviation “Eq.,” for “Equation.”

4. Figures and Tables

Every figure or table included in the submission should have a **non-embedded** reference to it within the text.

4.1 Figures

Place figures as close to their text reference as possible, preferably after the end of the paragraph of reference. DO NOT EMBED links in the text to figures or tables. In some cases, it will be necessary in final layout format for a figure to appear on a following or subsequent page, depending on its size and the positioning of other figures and tables nearby. Figures should have one double-space return separating them from the preceding text, rather than appearing on the next line, and be formatted to be “in line” with text. All figures must be electronically generated (not hand-drawn), and given sequentially-numbered captions beginning on the line below the figure.

Captions should be left-justified, in 9 pt. font size, and written with only the initial word capitalized (sentence capitalization). The Figure designation should be bolded, and do not abbreviate “Figure” in either the text or the caption. A period should follow the number of the figure. One double-space return should separate the caption from the text that follows it. The insertion of a sample figure (Figure 1) and caption is shown below.

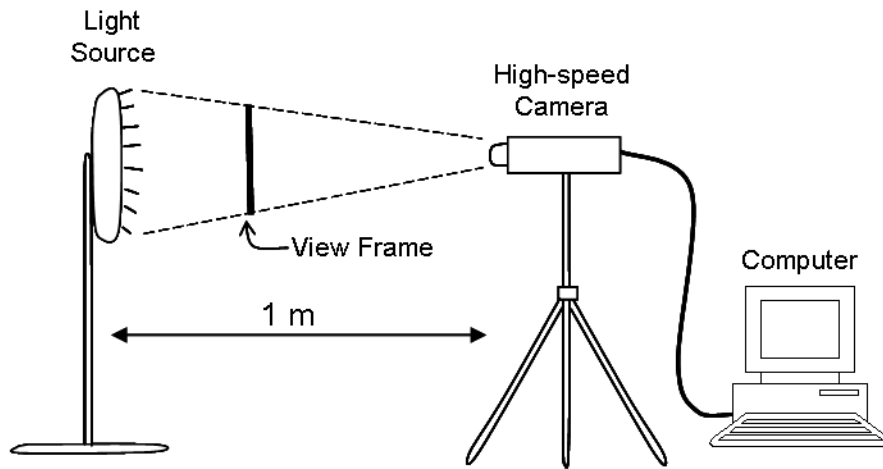

Figure 1. Enter the caption for your figure here.

4.2 Tables

Tables should also be kept as close to their text mention as possible, and separated from surrounding text by one double-space return. Each table must be numbered, titled, provided with a legend, and mentioned specifically in the text. (DO NOT EMBED links to tables or figures.) Tables should be arranged to fit on the final page-proof as a single column, if possible, but if necessary, the full width of the page may be used, in which case the table should be placed either at the top or bottom of a page. Material within the table may be typed in 9-pt. typeface in order to accommodate the information. Each table should have a sequentially numbered explanatory title placed above the table and left-justified, in initial caps and 9-pt. regular typeface. If more information is warranted pertaining to the Table itself, add an asterisk or numbered/lettered legend beneath the Table. See below for the formatting of an example table (Table 1).

Table 1. Sample Table Caption and Layout

θ	a	Λ	Perturbation type	τ	α	λ_{\perp}	n_{\perp}	n_{ϕ}
89.5	1.20	6	SV	5	0	0.398	144	2304
89.5	1.20	6	SV	5	90	3.981	2304	2304
89.5	1.20	6	NM	—	0	0.501	288	2304
89.5	12.0	6	NM	—	90	7.934	4608	2304

ACKNOWLEDGMENTS

An optional, brief paragraph of acknowledgments may be placed between the paper and the References section, or between the paper and its Appendices, as appropriate. In general, acknowledge only direct help in writing or research. Financial support (e.g., grant numbers) for the work done, or for an author, or for the laboratory where the work was performed is also best acknowledged here, rather than as footnotes to the title or to an author's name.

APPENDIX A: TITLE

Multiple appendices are labeled A, B, C, etc. If there is only one appendix, then an identifying letter is not necessary. If the appendix is bulky and formatting is more streamlined by placing it behind the References, that is acceptable. An appendix should be formatted in exactly the same way as the rest of the paper when sections and subsections are necessary. If there are equations in an appendix, number them as (A1), (A2), etc. Figure numbering also starts over with Figure A1, A2, etc.

$$x = \frac{2b \pm \sqrt{b^2 - 4ac}}{2c}. \quad (\text{A1})$$

REFERENCES

List references in alphabetical order by the Author's last name, without numbering. The first line should align with left margin, with subsequent lines for that entry indented. The next reference may be typed immediately on the next line without extra spacing or indentation. Please recall that all references listed here must also be cited in the text.

In the Reference section, all Author names may be included; this is different from in-text cites, in which only the first Author's last name is used, followed by "et al.," if there are more Authors. Use "n-dash" with no spaces, for page or date ranges, instead of hyphens. Dates should be in American format style, i.e., month/date/year.

Add all available online URLs for the source, as well as any available doi number or URL, as shown below. Always add the most recent date this source was accessed for your paper.

Abbreviate Journal titles as shown below.

Each reference citation should end with a period (.).

Sample references are provided below:

1) Online References –

AuthorLastName, FirstName I. [if known]. Title of Web Site or Page (Date [if known]): Available at: [http://www.\(URL\)](http://www.(URL))
(accessed Jun. 5, 2015).

2) Journal Articles –

Loxsom, F. and Kunkel, C. (1996): The Effect of Optical Aerosol Depth. *Amer. Satellite J.*, Vol. 10 (4), pp. 6–118. doi:
43-4592-348-9. Available at: www.xxx.com (accessed Oct. 10, 2018).

3) Proceedings –

Loxsom, F. (1996): The Effect of Optical Aerosol Depth, in *Proc. 24th Annu. Conf. of New Science*, Trenton, NJ, pp. 33-
-38.

4) Papers Presented at Conferences –

Loxsom, F. (1996): The Effect of Optical Aerosol Depth, presented at the IEEE Summer Power Meeting, Dallas, TX,
June 2–4. Paper ASX33.

5) Books –

Loxsom, F. (1996): *The Effect of Optical Aerosol Depth* (3rd ed.). Santa Fe, NM (and Country, if not US): McGraw-Hill.
doi: 33-2254-33XX.

6) Chapters/Articles in Edited Book –

Twiggs, R. (2008): Origin of CubeSat, in *Small Satellite: Past, Present and Future* (H. Helvajian and S.W. Janson, eds.)
El Segundo, CA: The Aerospace Press, pp. 151--173. doi: 34-2359-235932L38.

7) Thesis/Dissertation –

Author, J. K. (2010): Title of Thesis/Dissertation, Dept. of Electron. Eng., Osaka Univ., Osaka, Japan.

8) Unpublished Reference – (Not for listing in Reference section; only in-text cites.)

Author, J. K.: private communication, May 2010.